

CONTENT

1.0 Introducing the RVA Valve	Page 2
1.1 Operating Principles	Page 2
2.0 Installation	Page 3
2.1 Inspection before Installation	Page 3
2.2 Installation to the Pipeline	Page 4
2.3 Air Supply Recommendations	Page 5
2.4 Air Supply Pressure Requirements	Page 5
3.0 Operation	Page 6
4.0 Maintenance	Page 7
4.1 Removing the Elastomer Tube	Page 7
4.2 Installing the Elastomer Tube	Page 7
4.3 Installing the Gasket Seal	Page 8

Technical details subject to change without notice.

1.0 INTRODUCING RVA VALVE

This manual covers the installation, operation, and maintenance of the RVA air actuated valve.

1.1 Operating Principles

The air actuated RVA Valve features an elastomer tube inside a sealed valve body (see figure 1). When the interior of the valve body is pressurized 2 bar higher than the pressure inside the elastomer tube, the tube collapses and stops the flow of media through the valve. Relieving the pressure inside the sealed valve body causes the tube to spring back fully opened, and thus allows the flow of media through the valve.

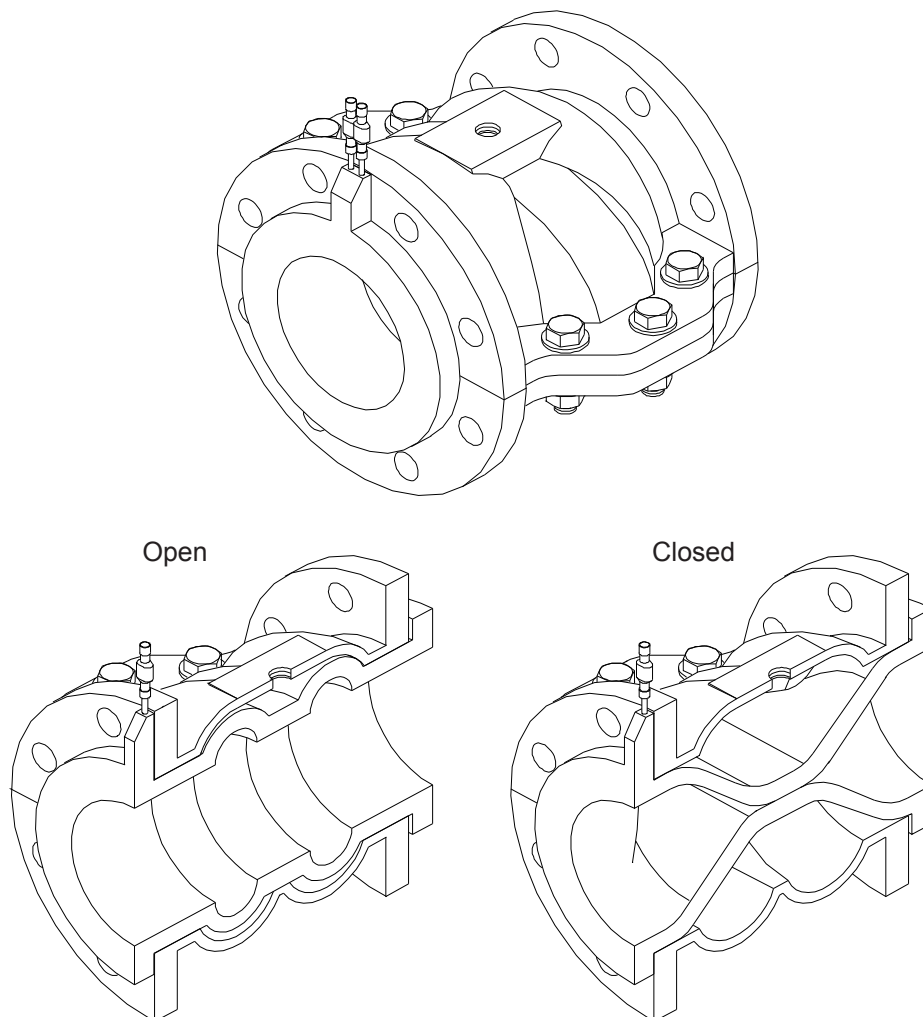

Figure 1: RVA Operating Principle

Technical details subject to change without notice.

2.0 INSTALLATION

Proper installation of the RVA Valve will maximize the life of the elastomer tube. Incorrect installation procedures may not only reduce the lifetime of the elastomer tube but may cause the RVA Valve to not operate at all.

2.1 Inspection Before Installation

Before installing the RVA Valve, please verify the following:

- 1) That there is a gasket between the valve body halves.
- 2) Gray/white marks on the outside flange of the elastomer tube line up within 5 degrees of the valve body split (see figure 2-1).
- 3) For installation onto a horizontal pipeline, be sure that the valve is installed with the split of the valve being horizontal. However in a vertical pipeline, the RVA valve can be installed in any orientation (see figure 2-2).

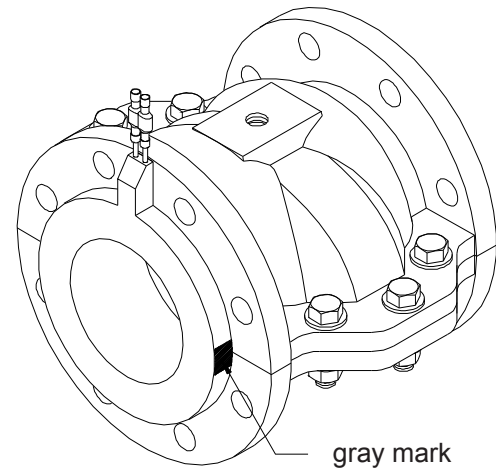

Figure 2-1: Tube Alignment

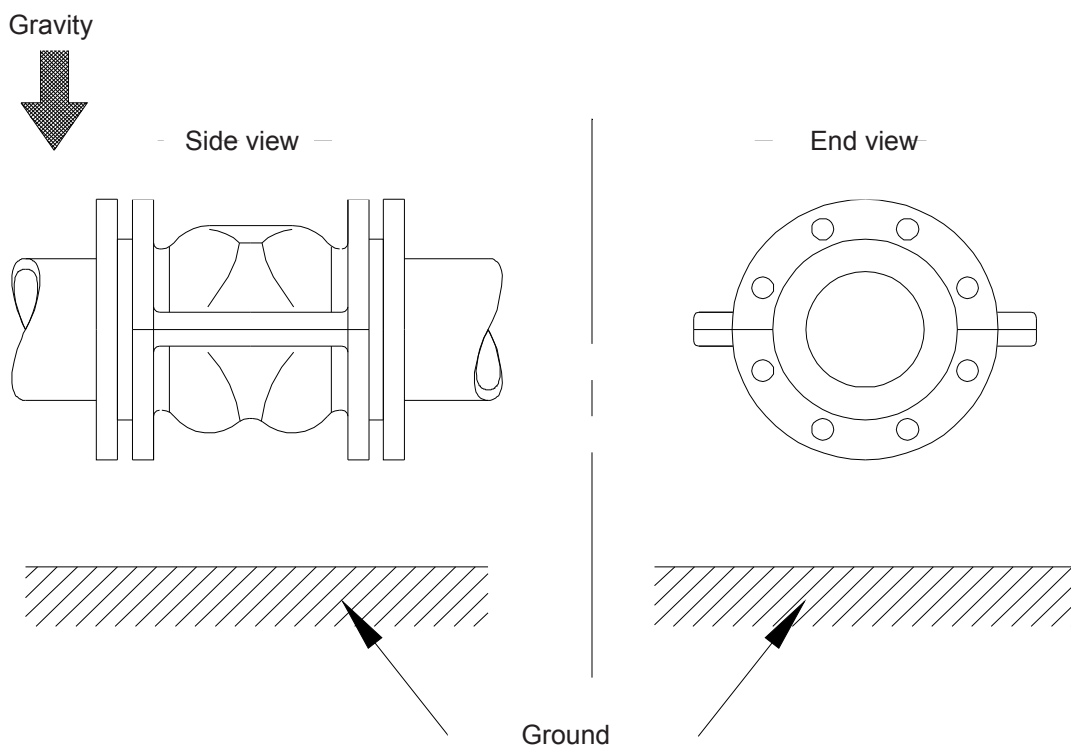

Figure 2-2: Installation Orientation for Horizontal Pipe

Technical details subject to change without notice.

2.2 Installation to the Pipeline

RVA Valves must have their flange bolts torqued to the proper specification. Too little torque and the valve will leak. Too much torque and the elastomer tube could be irreparably damaged. Refer to the instructions below.

Step 1:

Pipe flanges must be measured to insure they are parallel (see figure 2-3), maximum deviation from parallel A-B £ 1 mm. NOTE: Tightening bolts when flanges are NOT PARALLEL can cause damage and possible failure of the elastomer tube that serves as a gasket between the valve body and the pipe flanges.

STEP 2:

Torque all flange bolts in a star pattern; first to 50% of recommended values and then retorqued to 100% of recommended values (see table 1). Repeat star pattern torquing procedure 3 to 4 additional times at 100% torque values to finalize flange seals.

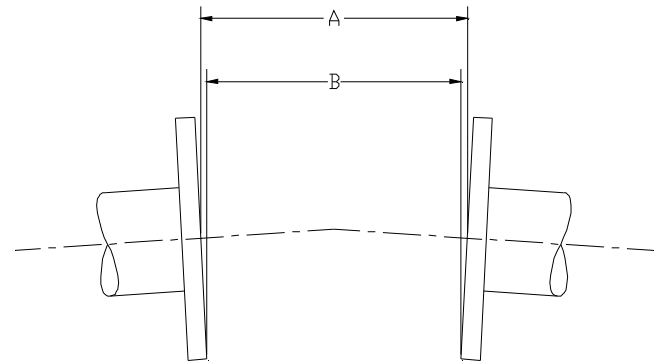

Max. deviation of pipe flanges from parallel A-B less than 1 mm

Figure 2-3: Parallel Flanges

Valve Size	No of bolts	Bolt Circle DIA	Thread Size	Bolt Torque (Nm)
DN 25	4	85	M12	9
DN 40	4	110	M16	12
DN 50	4	125	M16	15
DN 80	4	160	M16	18
DN 100	8	180	M16	18
DN 150	8	240	M20	25
DN 200	8	295	M20	30
DN 250	12	350	M20	30
DN 300	12	400	M20	40
DN 350	16	460	M20	40

Table 1. DIN PN 10 Recommended Flange Bolt Torque Specifications

Technical details subject to change without notice.

2.3 Air Supply Recommendations

For best operation of the RVA valve, it is recommended that the air supply should be clean, dry, and non-lubricated.

WARNING:

The oils in a lubricated air supply line may attack the elastomer so they should never be used with RVA valves.

2.4 Air Supply Pressure Requirements

To maximize the lifetime of the elastomer tube inside the RVA valve, the pressure in the air supply line should be regulated based on the graph below. Too little pressure and the RVA valve will not seal causing excessive wear to the elastomer tube. Too much pressure and the elastomer tube will be over-stressed.

IT IS BEST TO “TRAIN” THE ELASTOMER TUBE BY ACTUATING IT 15-20 TIMES BEFORE PLACING THE VALVE INTO SERVICE.

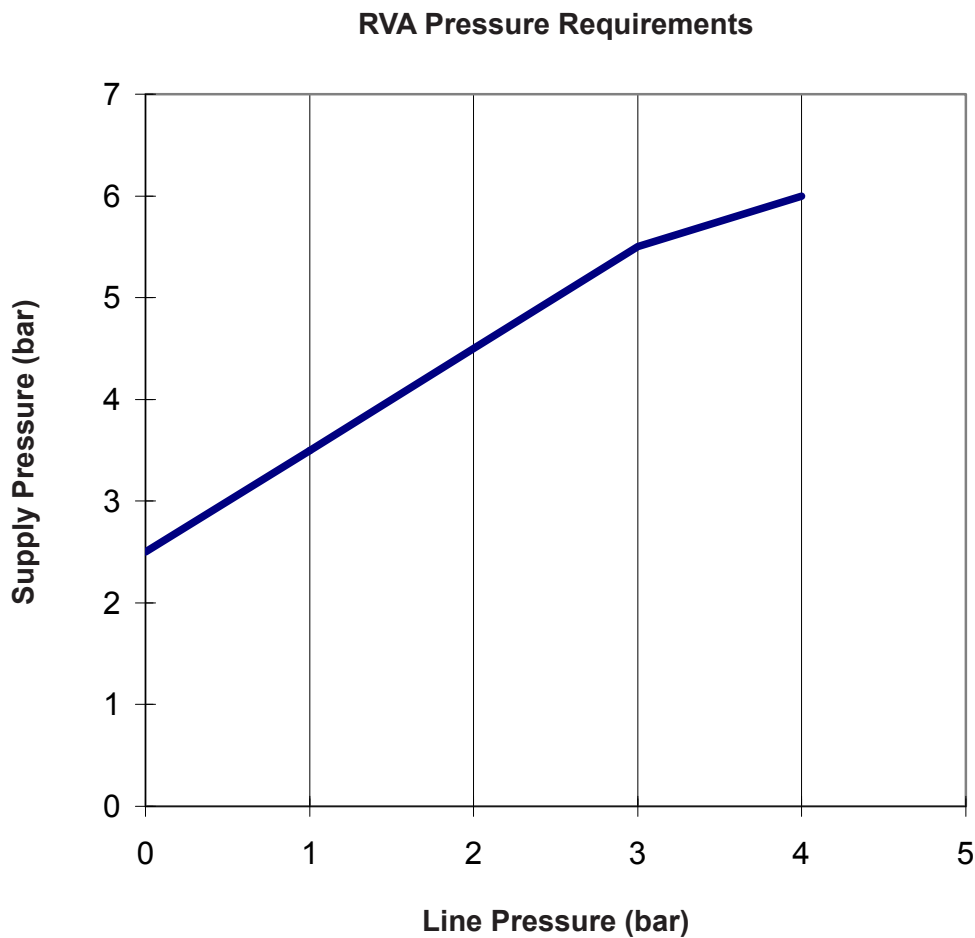

Technical details subject to change without notice.

3.0 OPERATION

Once the RVA Valve has been properly installed, it is ready for operation. A simple 3-way air valve is all that is needed to operate the RVA Valve. Refer to figure 3-1 below for a sample pneumatic circuit to operate the RVA Valve.

To close the RVA Valve:

Pressurize the inside of the valve body based on the graph found in section 2.4.

To close the RVA Valve:

Pressurize the inside of the valve body based on the graph found in section 2.4.

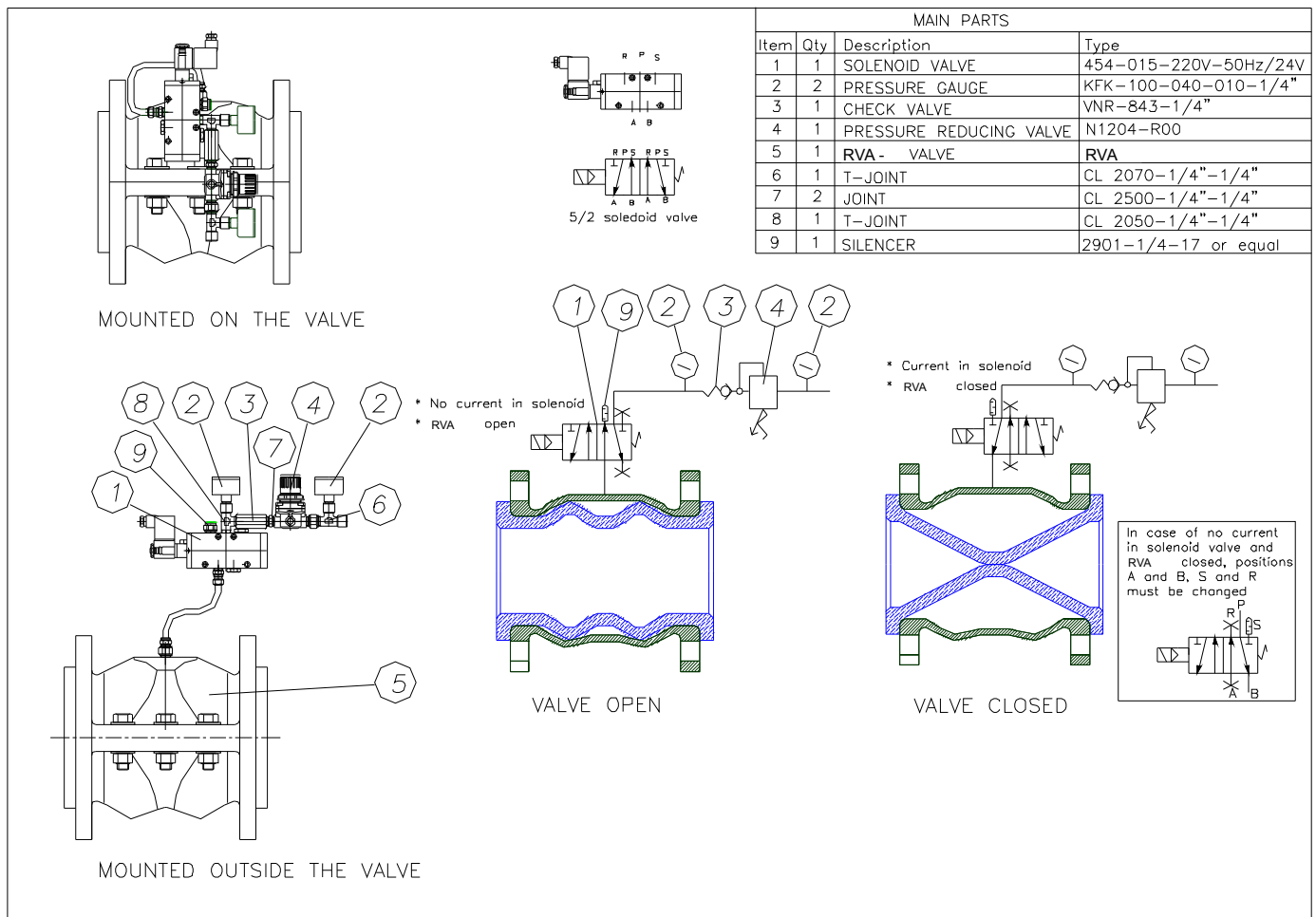

Figure 3.1. Example RVA Control

Technical details subject to change without notice.

4.0 MAINTENANCE

Maintenance of the RVA Valve involves changing the elastomer tube or changing the gasket between the valve body halves. A unique feature of the RVA Valve is that all these maintenance procedures can be done without removing the RVA Valve from the pipeline. Instructions below are for performing these maintenance tasks without removing the valve from the pipeline.

4.1 Removing the Elastomer Tube

- STEP 1: Disconnect the air supply from the RVA valve.
- STEP 2: Loosen (but do not remove) the flange bolts until they are hand-tight.
- STEP 3: Remove the flange bolts from the lower valve body only.
- STEP 4: Remove the bolts that secure the RVA valve body halves together and remove the lower valve body.
- STEP 5: The elastomer tube should be free enough to be removed.

4.2 Installing the Elastomer Tube

- STEP 1: Verify that the elastomer tube has gray/white marks on the outer edge of its flanges.
- STEP 2: Verify that the gasket seal between the valve body halves is intact. If not, proceed to section 4.3 to install a new gasket seal.
- STEP 3: Insert the elastomer tube inside one of the halves of the RVA valve. Be sure that the gray/white marks line up within 5 degrees of the split of the valve body.
- STEP 4: Bring the valve body halves together. Fasten the halves together evenly with bolts, nuts, and lock washers. To get a good seal between the valve body halves, the nuts and bolts should be tightened equally.
- STEP 5: Insert flange bolts into the lower half of the RVA valve body.
- STEP 6: Torque the flange bolts as instructed in section 2.2.

Technical details subject to change without notice.

4.3 Installing the Gasket Seal

- STEP 1: Follow the steps in section 4.1 to disassemble the RVA valve and gain access to the gasket seal.
- STEP 2: Remove the old seal from the valve body half. Afterwards, be sure that the surfaces of the valve body halves are clean and free of grease, oil, solvents, etc.
- STEP 3: 5 mm wide PTFE teflon joint sealant gasket tape is sufficient to seal the valve body halves. Apply the tape to only one of the valve body halves, not both. The tape should follow the interior perimeter of the valve body half with a 1/16" to 1/8" extension beyond the body (see figure 4-1).
- STEP 4: Follow the steps in section 4.2 to reassemble the RVA valve.

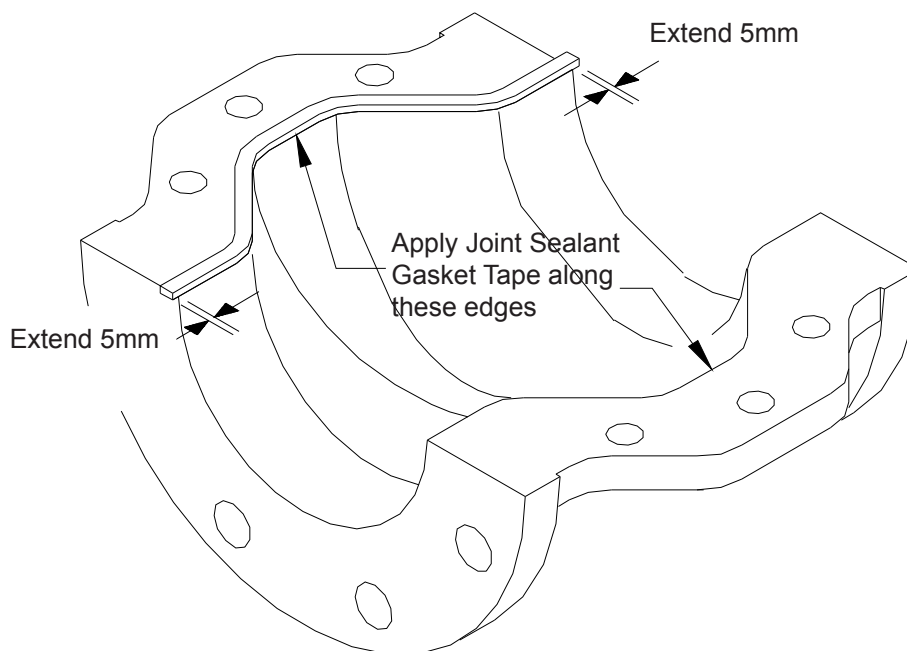

Figure 4-1: Joint Sealant Gasket Tape Application

Technical details subject to change without notice.